

VERSAVAC™

Distribution Capacitor Switch

Porcelain or
Polymer
Housing!

15 kV - 38 kV



Longest Life of ANY Distribution Capacitor Switch
with 50,000 Maintenance-Free Operations!

Features/Benefits

The Joslyn VerSaVac™ is a completely sealed, long life vacuum switch that provides an operational life of over 100,000 (50,000 open/close) maintenance-free operations. This results in an operational life five times greater than other switches used for pole top capacitor switching. The VerSaVac was specifically designed as a replacement for maintenance intensive oil switches and can be used as a direct replacement on existing banks or supplied by capacitor manufacturers on new banks. Using the VerSaVac will result in substantial savings from reduced maintenance and maximized bank uptime, and will also improve Power Quality.

NO OIL OR GAS

Vacuum interruption and solid dielectric "Joslyte" insulation around vacuum bottle. This material is non-hydroscopic and absorbs stresses from thermal expansion and shock. VerSaVac has been field proven for over 35 years.

COMPATIBILITY

VerSaVac switches are compatible with existing oil switch or vacuum switch installations.

RELIABILITY

Proven design with over 150,000 worldwide installations and over 20 years of operational experience.

SYNCHRONIZED OPERATION

The fast and repeatable solenoid operating mechanism ensures all phases will operate within 1/4 cycle, unlike slow motor operated devices, reducing the recovery voltage when the bank is being switched off, which in turn reduces the electrical stress on the insulation of the capacitor bank.

EXCEEDS ELECTRICAL REQUIREMENTS OF ANSI C37.66

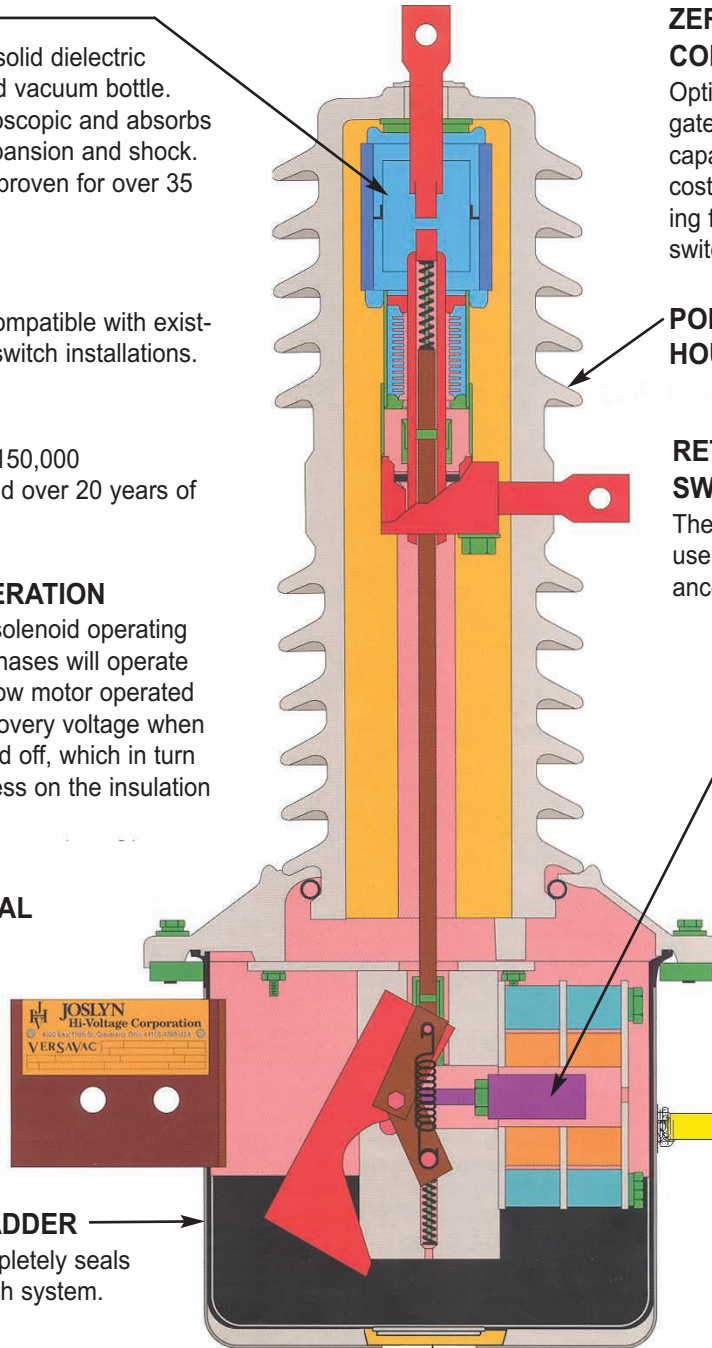

ZERO VOLTAGE CLOSING (ZVC) CONTROL

Optional Zero Voltage Closing control, mitigates transients associated with bringing capacitor banks online. Virtually eliminates costly customer equipment damage resulting from voltage spikes created when switching capacitor banks.

PORCELAIN OR POLYMER HOUSING

RETROFITS TO EXISTING OIL SWITCH POWER SUPPLY & WIRING

The new low energy mechanism allows the use of standard supply transformer impedances and existing 14AWG oil switch wiring.*

LONG LIFE SOLENOID MECHANISM

Provides 100,000 operations (50,000 open/close)

MANUAL TRIP LEVER (OPTIONAL)

Trip lever is NOT mechanically connected to the operating mechanism, eliminating wear during normal operation.

BLADDER
Completely seals switch system.

POSITION INDICATOR (Bottom View)

Highly visible reflective lettering indicates switch position.



*See I 750-271 Single Phase VerSaVac Installation and Operating Procedure for complete details

Ratings

Exceeds Electrical Requirements of ANSI C37.66

Continuous Current: 200 Amperes
 Shorttime Current: 6 kA (1/2 sec), 4.5 kA (1 sec)
 Asymmetrical Momentary/Making Current: 9 kA Asymmetrical RMS/23 kA Peak
 Peak Inrush Current Limit for Parallel or Back-to-Back Switching Applications: 6 kA
 Control Voltages: 120 VAC, 240 VAC *(see accessories)
 Minimum Operating Voltage: 80 VAC, 160 VAC
 Recommended Control Pulse Time: 100ms
 Auxiliary Contact Rating: 15 A @ 120 VAC, 0.5A @ 125 VDC
 Creepage Distance:

95 kV BIL - 12 5/8" (321 mm)
 125 kV BIL - 17 3/16" (437 mm)
 150 kV BIL - 19 7/16" (494 mm)
Note: 150 kV Line-to-ground BIL available in all models.
 Extra creepage insulation available.

OPTIONAL TRIP LEVER LOCATIONS

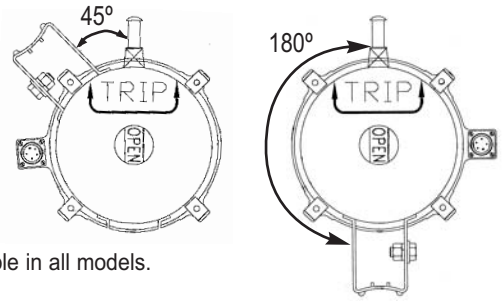

Ordering Information

GROUNDING SYSTEMS

Max System Voltage (kV)	Line-to-ground/ Open -gap BIL	Auxiliary Contacts	No. of Pins in Connector	Trip Lever Location	Power Frequency AC Withstand Dry/Wet kV (RMS)	Part Number Porcelain (120 VAC)	Part Number Polymer (120 VAC)	Part Number For Use with ZVC Control (120 VAC)
15.5	95/95	1 (B)	5	N/A	35/30	3148X0302G1	3148X2006G1	3148X0723G1
15.5	95/95	2 (1A 1B)	6	N/A	35/30	3148X0302G3	Consult Factory	Consult Factory
15.5	95/95	1 (B)	5	45°	35/30	3148X0636G1	3148X2009G1	Consult Factory
15.5	95/95	1 (B)	5	180°	35/30	3148X0637G1	3148X2010G1	3148X0723G3
15.5	95/95	2 (1A 1B)	6	180°	35/30	3148X0637G3	Consult Factory	3148X0723G5
22.5	125/125	1 (B)	5	45°	60/50	3148B1060G1	Consult Factory	Consult Factory
22.5	125/125	1 (B)	5	180°	60/50	3148B1061G1	3148B2007G1	3148B0960G4
27.5	125/95	1 (B)	5	N/A	60/50	3148X0302G13	3148X2006G13	3148X0723G2
27.5	125/95	1 (A)	5	N/A	60/50	3148X0302G26	3148X2006G26	Consult Factory
27.5	125/95	2 (1A 1B)	6	N/A	60/50	3148X0302G24	Consult Factory	3148X0723G16
27.5	125/95	1 (B)	5	45°	60/50	3148X0636G13	Consult Factory	Consult Factory
27.5	125/95	1 (B)	5	180°	60/50	3148X0637G13	3148X2010G13	3148X0723G4
27.5	125/95	2 (1A 1B)	6	180°	60/50	3148X0637G23	Consult Factory	Consult Factory
38	125/125	1 (B)	5	N/A	70/60	3148B0947G1	Consult Factory	3148B0960G1
38	125/125	1 (B)	5	45°	70/60	3148B1060G1	Consult Factory	Consult Factory
38	125/125	1 (B)	5	180°	70/60	3148B1061G1	3148B2007G1	3148B0960G4
38	150/125	1 (B)	5	45°	70/60	3148B1060G2	Consult Factory	Consult Factory
38	150/125	1 (B)	5	180°	70/60	3148B1061G2	Consult Factory	Consult Factory
38	150/125	1 (B)	5	N/A	70/60	3148B0947G5	3148B2008G5	3148B0960G2

UNGROUNDING SYSTEMS

Max System Voltage (kV)	Line-to-ground/ Open -gap BIL	Auxiliary Contacts	No. of Pins in Connector	Trip Lever Location	Power Frequency AC Withstand Dry/Wet kV (RMS)	Part Number Porcelain (120 VAC)	Part Number Polymer (120 VAC)	Part Number For Use with ZVC Control (120 VAC)
12.47	95/95	1 (B)	5	45°	35/30	3148X0636G1	3148X2009G1	Consult Factory
12.47	95/95	2 (1A 1B)	6	45°	35/30	3148X0636G3	Consult Factory	Consult Factory
12.47	95/95	1 (B)	5	180°	35/30	3148X0637G1	3148X2010G1	3148X0723G3
12.47	95/95	2 (1A 1B)	6	180°	35/30	3148X0637G3	Consult Factory	3148X0723G5
15.5	95/95	1 (B)	5	N/A	35/30	3148X0302G1	3148X2006G1	3148X0723G1
15.5	95/95	2 (1A 1B)	6	N/A	35/30	3148X0302G3	Consult Factory	Consult Factory
22.5	125/125	1 (B)	5	45°	60/50	3148B1060G1	Consult Factory	Consult Factory
22.5	125/125	1 (B)	5	180°	60/50	3148B1061G1	3148B2007G1	3148B0960G4
27.5	125/125	1 (B)	5	N/A	60/50	3148B0947G1	Consult Factory	3148B0960G1
27.5	150/125	1 (B)	5	N/A	60/50	3148B0947G1	Consult Factory	Consult Factory

Accessories

Junction Boxes, Cable Assemblies, Current Sensors, Mating Connectors, Animal Protectors (2 per switch)
 Under Voltage Trip Control, Zero Voltage Control (ZVC), 125 DC Control Interface

Capacitor Controls

AUTOCAP™ AC100

The AC100 is a programmable capacitor control with voltage, time, and temperature control with an override function. The light weight, low profile enclosure has an integral meter base. The front panel is easy to operate and setup.



FISHER PIERCE® AUTOCAP™ 4400 NOW AVAILABLE WITH SMARTLINK™ 4000

Microprocessor based control featuring Adaptive functions which can allow the unit to program itself. Programmable control modes include VAR, current, voltage, time and temperature, as well as override and protective functions. SmartLink 4000 adds reliable, cost effective 2-way communications and provides automatic alarm or status reporting sent via email, pager, or text message.

FISHER PIERCE AUTOCAP™ 4500

Microprocessor based control including all features of the Series 4400 with data radios for two-way communications. A dedicated communications microprocessor and flash memory allow the use of data radios cellular, and modem communication technologies. The result is a powerful tool for discrete feeder management, data gathering, trouble shooting and system evaluation analysis.



ZERO VOLTAGE CLOSING CONTROL

Improves power quality and capacitor life by eliminating capacitor closing transients. Closes three poles independently synchronized with zero voltage in each phase to eliminate over-voltages and reduce inrush current.

See I 750-239 Zero Voltage Closing Instruction Manual

FISHER PIERCE SERIES 2695D

The Fisher Pierce Series 2695D microprocessor based Digital VHF radio capacitor switch is designed for one-way control of distribution switch-type capacitor banks. The 2695D is available in magnetically latching or momentary pulsed output relay types. The switch can be operated from existing radio based capacitor control systems or from the Fisher Pierce 2635 code generator.



4000 E. 116th St. Cleveland, OH 44105 USA
Phone: (216) 271-6600 Fax: (216) 341-3615
www.joslynhivoltage.com Email: jhinfo@tnb.com